

DUPLEX-S 525, 900, 1400

multi-purpose compact heat recovery ventilators

Ventilation units DUPLEX-S 525, 900 and 1400 with a new original patented design are intended for the comfortable ventilation with the highest recovery efficiency, hot-air circulation heating and cooling of all types of civil and residential buildings.

Units are supplied in indoor version for mounting on a window sill or under the ceiling in many configurations.

Units are designed as compact aggregates containing in a single cabinet two independently powered radial fans with flexibly mounted motors, a highly efficient counterflow heat recovery exchanger with a large heat-exchange surface, slide-out filters for supply and extraction air with class G4 or F7 (cassette or mesh) and drainage tanks.

Optionally, units are fitted with an internal circulation damper with a servo drive, a by-pass damper with a servo drive, a hot-water heater, a direct or water cooler and other optional accessories.

On request units may be equipped with a full measurement and control system.

Unit cabinets are made up from painted metal sheet in a white finish with polyurethane filling ($U = 0,95 \text{ Wm}^{-2}\text{K}^{-1}$).

The front opening door ensures easy access to all aggregates and filters. Inlet and outlet necks are circular, optionally rectangular in DUPLEX-S 1400 units.

Optionally, units may be fitted with energy-saving EC filters possible to adjust for constant flow.

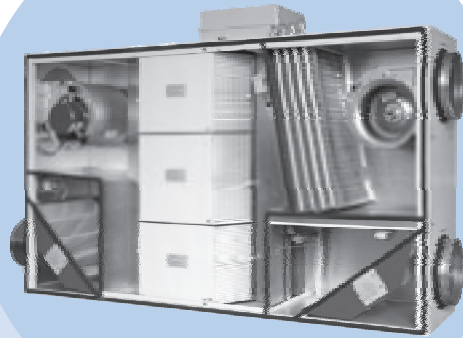

DUPLEX-S 525, 900, 1400

DUPLEX-S advantages

- A very low depth especially suitable for ceiling installations.
- The truly compact design of new units ensures space saving up to 60 % in comparison with modular units
- Low purchase cost
- Window-sill and ceiling installation
- Low noise levels
- Low weight
- Low power consumption
- High recovery efficiency up to 90 %
- Complete integrated control systems in several types depending on application demands, control fully integrated into the unit

AVAILABLE MODIFICATIONS (CAN BE COMBINED)

- | | | | |
|-----|--------------------------------------|-------|--|
| - B | with built-in by-pass | - CHF | with built-in DX cooling coil |
| - C | with built-in mixing damper | - CHW | with built-in chilled water cooling coil |
| - T | with built-in hot water heating coil | - CHP | ready for built-in cooling system |

OPERATING MODES OF THE DUPLEX UNITS

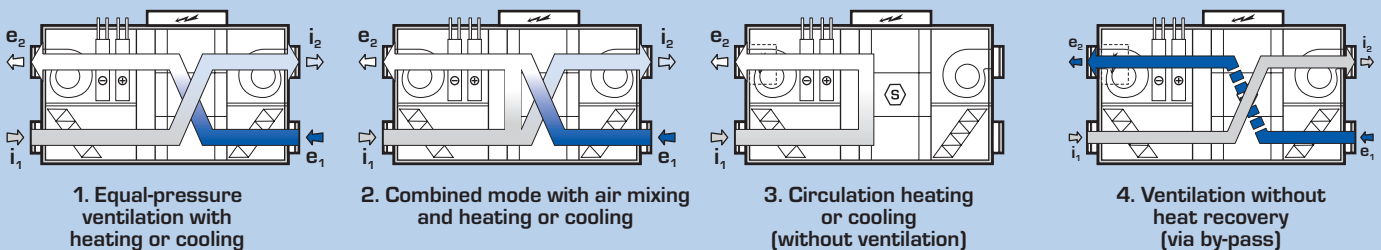

- e₁ ... Inlet of fresh outdoor air – outside air
 → e₂ ... Outlet of fresh filtered air – supply air

- i₁ ... Inlet of stale air – return air
 → i₂ ... Outlet of stale air – exhaust air

SELECTION SOFTWARE



For detailed selection of Duplex units, accessories and control system we recommend to use our special selection software. To select a heat recovery exchanger you can use our special selection software. Download it from our webpage www.atrea.cz or contact us at our mail address.



UNIT VENTILATORS & HEAT RECOVERY DIVISION

ATREA s.r.o., V Aleji 20
 466 01 Jablonec n. N.
 Czech Republic



www.atrea.cz

Phone: +420 483 368 111
 Fax: +420 483 368 112
 E-mail: atrea@atrea.cz

PERFORMANCE CURVES

TECHNICAL DATA

	type	DUPLEX-S 525	DUPLEX-S 900	DUPLEX-S 1400
supply air – max. ¹⁾	m ³ h ⁻¹	550	980	1 425
exhaust air – max. ¹⁾	m ³ h ⁻¹	515	890	1 290
heat recovery efficiency ²⁾	%	see diagram	see diagram	see diagram
weight ³⁾	kg	78 – 92	95 – 111	126 – 146
number of fans	-	2	2	2
voltage	V	230	230	230
frequency	Hz	50	50	50
max. power input	W	2x 175	according to fan type	according to fan type
speed	rpm ⁻¹	1 700	according to fan type	according to fan type
max. cooling capacity „CHW“ ⁴⁾	kW	see diagram	see diagram	see diagram
max. cooling capacity „CHF“ ⁴⁾	kW	see diagram	see diagram	see diagram
filtration class (standard)	-	G4	G4	G4

¹⁾ maximum volume flow through units at zero external pressure – see graph

²⁾ according to volume-flow – see graph

³⁾ according to selected accessories

PERFORMANCE CURVES

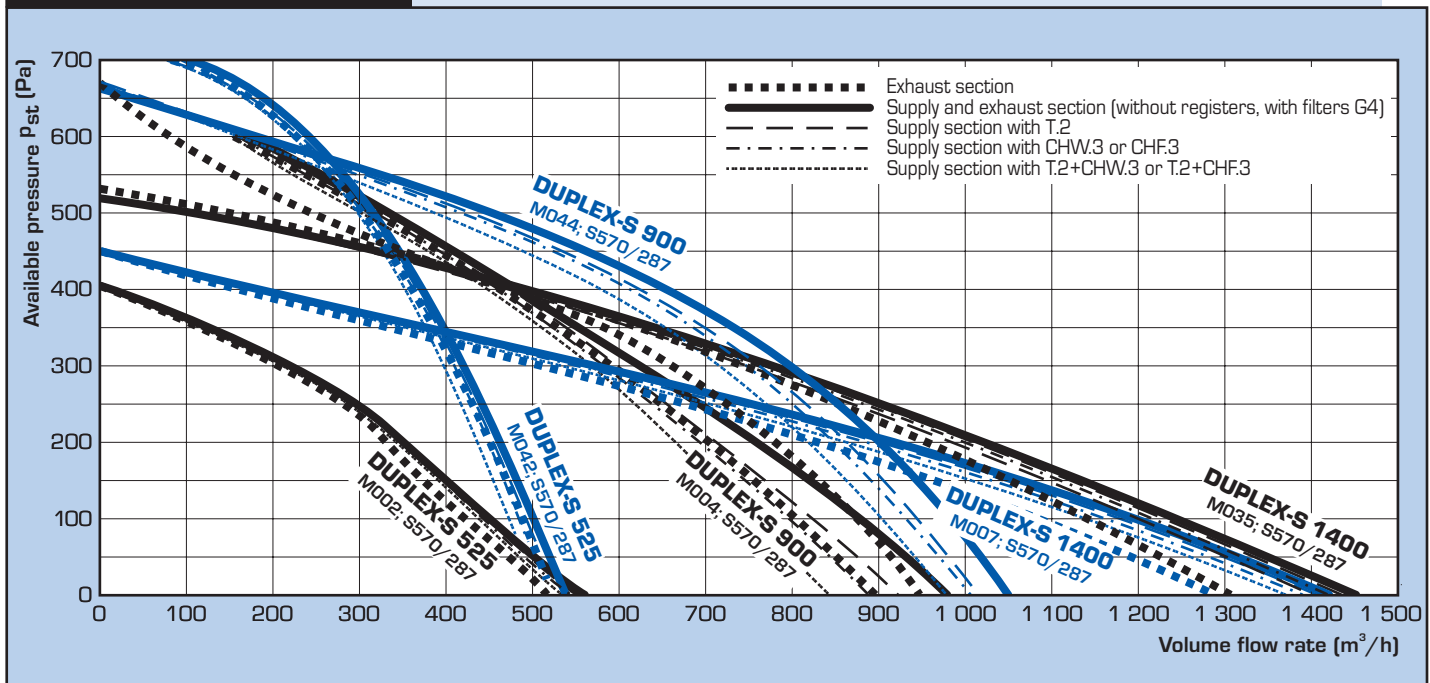

HEATING AND COOLING CAPACITY, HEAT RECOVERY EFFICIENCY

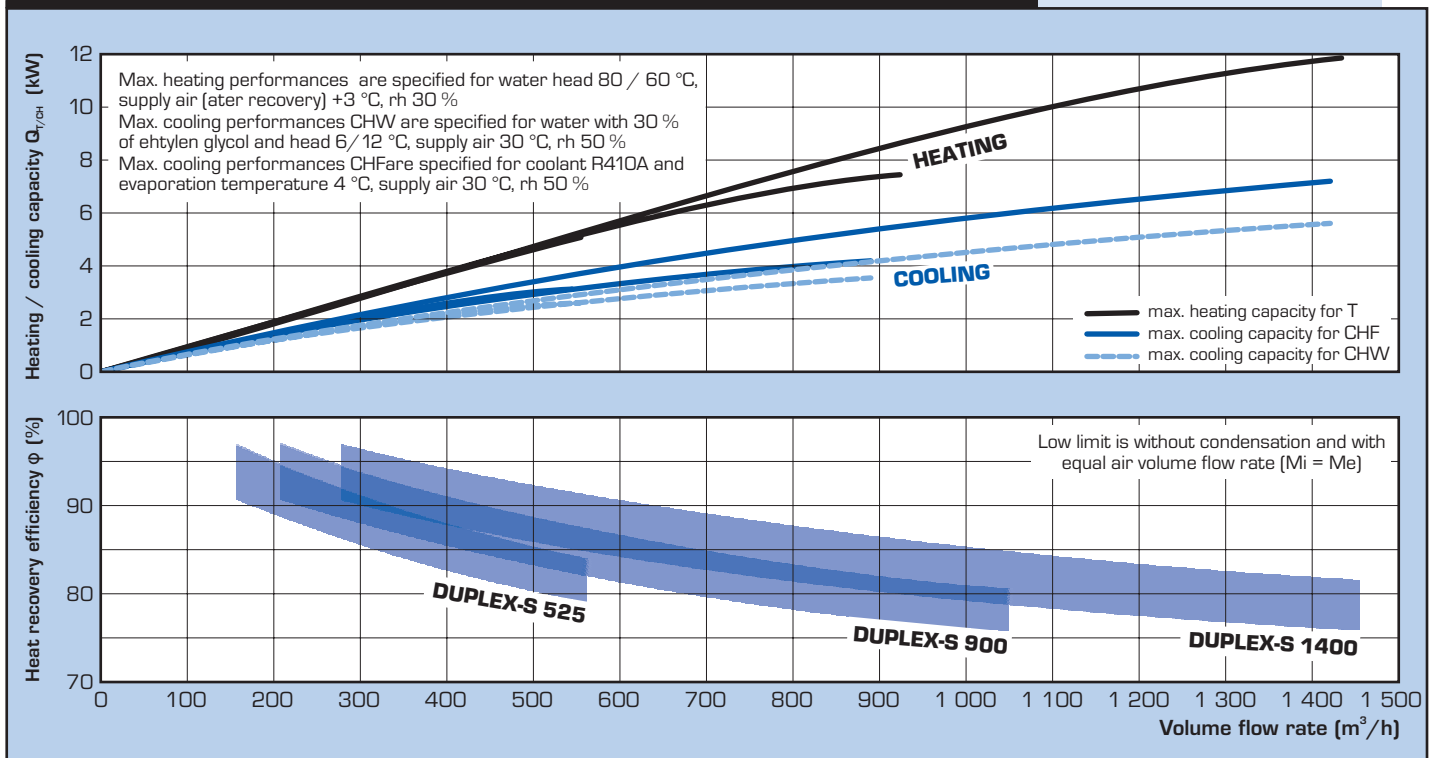

DIMENSIONS

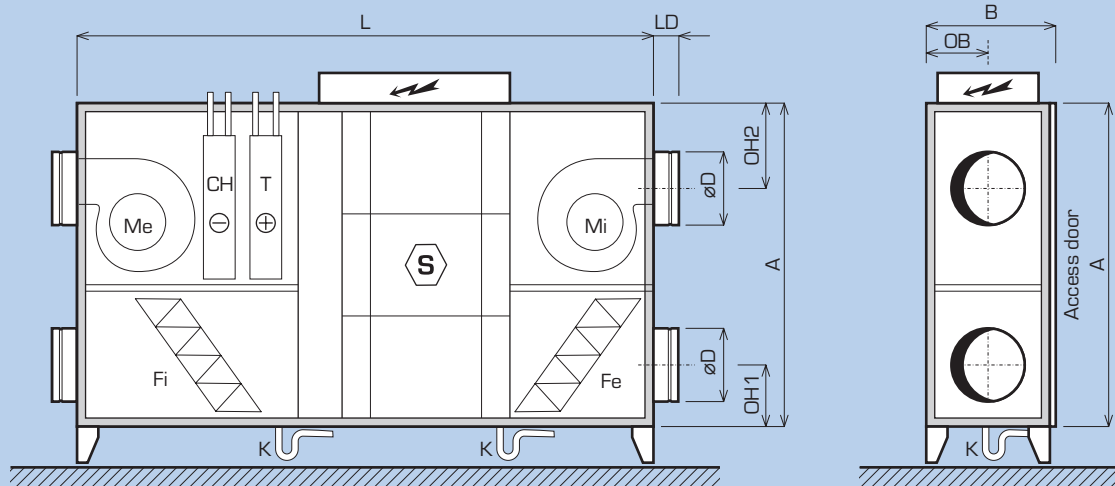

		DUPLEX-S 525	DUPLEX-S 900	DUPLEX-S 1400	
distance A	mm	745	950	1 100	
distance B	mm	365	365	430	
length L	mm	1 450	1 650	1 970	
drain connection K	mm	$\varnothing 22$ (for Position 10/x, 11/x), $\varnothing 32$ (for Position 30/x, 31/x)			
connection ports					
rectangular - distance Y x X	mm	not possible	not possible	(250 x 250) to (315 x 315)	
diameter D	mm	200	250	250	to 315
port with damper LH2	mm	160	185	185	220
inlet port axis OB	mm	180	162	215	215
inlet port axis OH1 - inlet	mm	135	162	200	200
inlet port axis OH2 - outlet	mm	230	310	170	200
Flange LD	mm	60	60	60	80

Find detailed information on all dimensions in a specialized design program for DUPLEX units.

PORT TYPES AND DIMENSIONS

CIRCULAR NECKS (DUPLEX-S 525, 900, 1400)

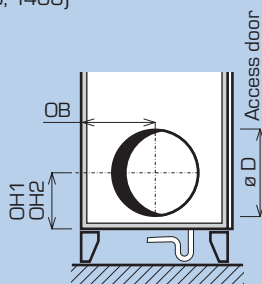

basic port
(inlet, outlet)

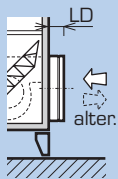

port with flexible connection
(max. length)
(inlet, outlet)

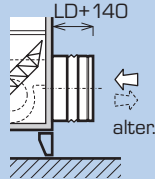

basic port port with damper
(inlet only)

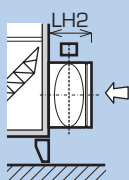

port with damper and flexible connection
(inlet only)

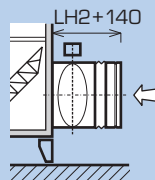

RECTANGULAR NECKS (DUPLEX-S 1400 ONLY)

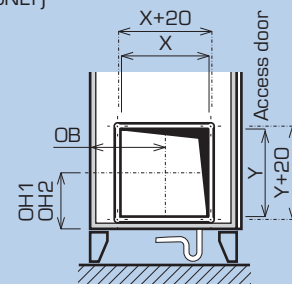

basic port
(inlet, outlet)

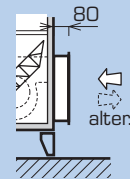

port with flexible connection
(max. length)
(inlet, outlet)

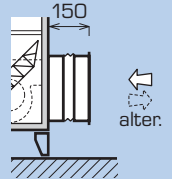

basic port port with damper
(inlet only)

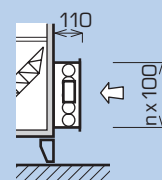

port with damper and flexible connection
(inlet only)

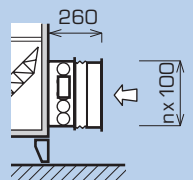

INSTALLATION CONFIGURATION

POSITION AND CONNECTION PORTS CONFIGURATION

DUPLEX-S units 525, 900 and 1400 are supplied in a range of configurations to facilitate their mounting in the engine room or under the ceiling in corridors, sanitary facilities etc.

As a result it is much easier to install DUPLEX units in otherwise cramped conditions.

DUPLEX units are characterized by a wide variety of configurations and neck sizes - in addition, all necks may be optionally fitted with

flexible flanges, inlet necks may be equipped with closing dampers on request.

Integrated control switchboards are generally fitted on the side of the unit (see the drawing). Switchboards on a cable may be supplied to order (optional length 3 to 6 metres).

FLOOR-STANDING HORIZONTAL POSITION

Position 10 and 11 – access door side view

Possible neck configurations:

DUPLEX-S 525	with fans M002: only 10/0; 10/2; 10/8; 10/10; 11/0; 11/2; 11/8; 11/10
DUPLEX-S 525	with fans M042: only 10/0; 11/0
DUPLEX-S 900	with fans M003, M004, M044: only 10/0; 11/0
DUPLEX-S 1400	with fans M005, M007, M035: only 10/0; 10/2; 10/8; 10/10; 11/0; 11/2; 11/8; 11/10

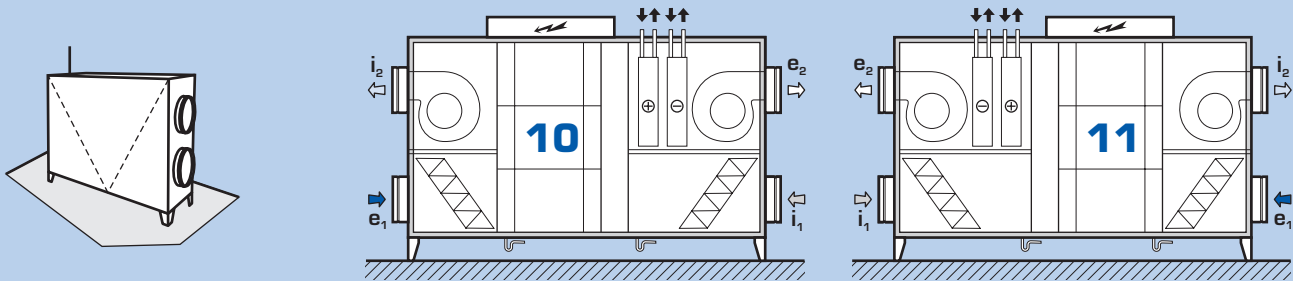

Find the detailed drawings of all neck configurations in a separate project document.
For a detailed design use a specialized design program for DUPLEX units.

CEILING-SUSPENDED POSITION

Position 30 and 31 – top view

Possible neck configurations:

DUPLEX-S 525	with fans M002: 30/0 to 30/15; 31/0 to 31/15
DUPLEX-S 525	with fans M042: 30/0, 30/1, 30/4, 30/5 a 31/0, 31/1, 31/4, 31/5
DUPLEX-S 900	with fans M003, M004, M044: only 30/0; 30/1; 30/4; 30/5; 31/0; 31/1; 31/4; 31/5
DUPLEX-S 1400	with fans M005, M007, M035: 30/0 až 30/15; 31/0 to 31/15

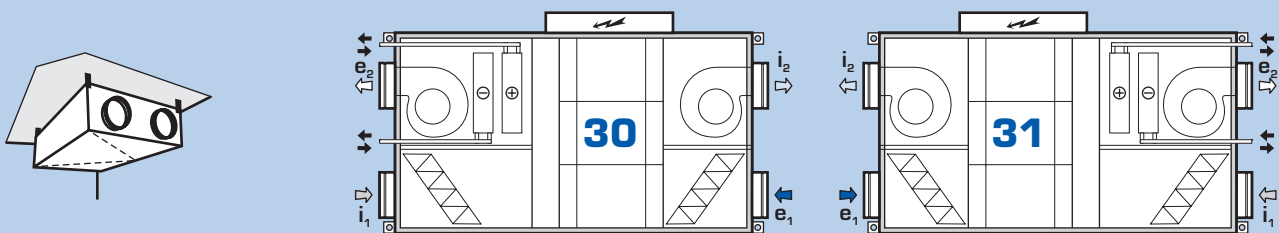

Find the detailed drawings of all neck configurations in a separate project document.
For a detailed design use a specialized design program for DUPLEX units.

MANIPULATION SPACE

When installing DUPLEX units it is necessary to allow for recommended free manipulation space around the unit. Minimum space of 150 mm is needed under a unit to install a DN 22 / DN 32 condensate drain pipe. A trap of minimum height of 150 mm must be installed before connecting the pipe to a building sewer. The recommended space is easily ensured when delivered standard base steel legs are used.

Unit front service space is needed for opening access door, filter removal and access to all components for maintenance. Respective data sheets show the minimum space for hinged door (easier access), and quick lock door (more difficult access). Minimum manipulation space on the control panel side is 600 mm for all units.

Units equipped with heating/cooling coil hydraulic kit require free manipulation on the kit side.

Door-side manipulation space

FLOOR-STANDING HORIZONTAL

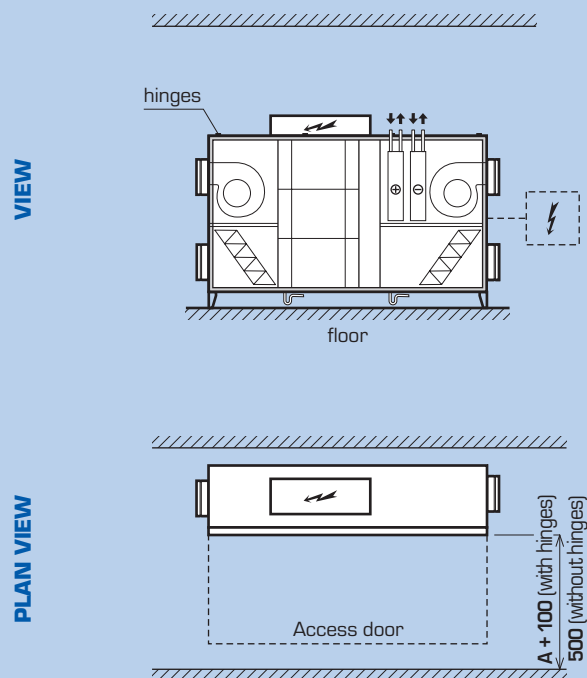

CEILING-SUSPENDED

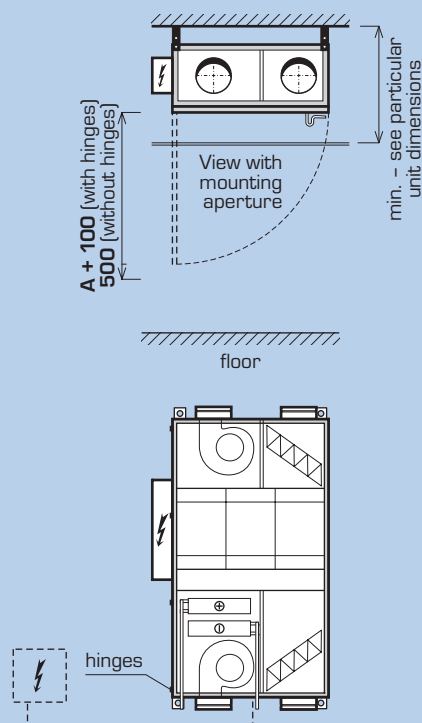

Accessory-side manipulation space

Control modules

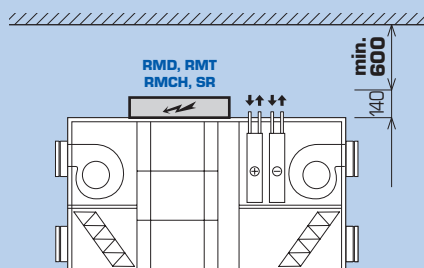

Hydraulic kits

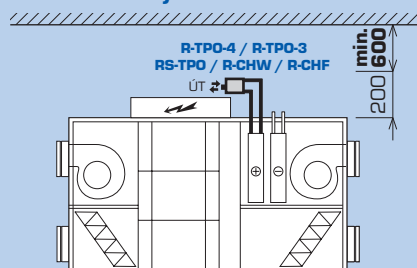

SOUND POWER LEVEL L_w (dB)

	dB(A)	125 Hz	250 Hz	500 Hz	1 kHz	2 kHz
DUPLEX-S 525, M002						
inlet	51,6	62,0	50,7	47,7	40,3	40,3
outlet	71,9	75,0	69,5	63,5	65,0	66,3
unit	64,3	63,1	63,3	63,6	58,3	53,9
DUPLEX-S 900, M004						
inlet	61,8	71,6	63,9	55,3	55,3	49,3
outlet	76,5	82,9	77,9	72,3	69,3	67,6
unit	58,9	67,2	61,3	56,0	50,9	48,1
DUPLEX-S 1400, M035						
inlet	58,0	67,7	59,1	50,7	50,4	45,7
outlet	74,0	78,9	73,2	69,9	68,6	64,2
unit	59,1	63,3	59,0	56,1	54,4	49,6
DUPLEX-S 1400, M007						
inlet	58,6	73,7	54,1	46,4	44,4	38,4
outlet	73,4	82,1	70,7	68,1	67,1	65,4
unit	59,3	68,1	59,4	54,8	54,5	49,0

SOUND PRESSURE LEVEL $L_{p,1}$ (dB)

	dB(A)	125 Hz	250 Hz	500 Hz	1 kHz	2 kHz
DUPLEX-S 525, M002						
unit	53,3	52,2	52,3	52,6	47,3	42,9
DUPLEX-S 900, M004						
unit	47,9	56,2	50,3	45	39,9	37,1
DUPLEX-S 1400, M035						
unit	48,1	52,3	48	45,1	43,4	38,6
DUPLEX-S 1400, M007						
unit	48,3	57,1	48,4	43,8	43,5	38,0

The sound pressure level is measured at 1 m from the respective unit.

See the design software for more data at different operational points or with different fans.

MODIFICATIONS

DUPLEX-S - BASIC CONFIGURATION

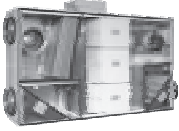

Cabinet

Unit cabinets are made up from painted sheet metal and polyurethane filling 22 mm thick, with thermal resistance $U = 0.95 \text{ Wm}^2\text{K}^{-1}$. The front door ensures easy access to all integrated aggregates and filters.

DUPLEX-S xxx



Fans

Supply and extraction radial fans with flexibly mounted electric motors.

Me.xxx; Mi.xxx



Air-to-air heat recovery exchanger

Removable counterflow recovery exchangers from thin-walled plastic boards with high efficiency.

S.800/560

DUPLEX-S - DESCRIPTION OF ACCESSORIES



By-pass („B“)

Recovery exchanger by-pass on the side of supply air, incl. a servo drive. Open by-pass automatically closes flow through the recovery exchanger.

B.x



Mixing damper („C“)

Built-in opposed-blade damper including BELIMO 230 V actuator. It enables to mix fresh and stale (internal) air in 0 to 100 % range. Along with the mixing damper, a shut-off damper without spring return function must always be installed at output e.g.,. Should the unit be equipped with a heating coil (DUPLEX-S-TC) and draft could occur in the duct system during power failure with the damper stuck open, it is necessary to install separate shutoff damper with spring-return function into the duct close to an air intake. The damper is controlled by the unit control.

C.x



Hot water heating coil („T“)

Built-in water-to-air three-row (possibly five-row) heating coil; made of copper pipes and aluminum fins. Designed for systems up to 110 °C and 1,0 MPa. The coil is standardly equipped with flexible connection and a steam-gas capillary thermostat for freeze protection. Units in modification T (with heating coil) must be equipped with e.g., supply air shutoff damper; an actuator with spring-return function (BELIMO LF 230 V) is recommended. A coil hydraulic kit for heating capacity control of R-TPO4, R-TPO3 or RS-TPO type can be supplied with the coil upon request. Attention - the coil of rooftop units must always be protected against freezing by a water-glycol mixture.

T.x



Provision for cooling („CHP“)

Provision for the additional mounting of a water cooler or a direct evaporator. DUPLEX-S units 525, 900 and 1400 may always be additionally fitted with a cooler. Attention - if a cooler is to be additionally mounted, safe access and a sufficient handling space must be ensured. Ceiling units must be disassembled for the installation of a cooler.

CHP



Direct expansion (DX) coil („CHF“)

A built-in coil made of copper pipes and aluminum fins, including a condensate pan with individual condensate drainage and a pressure switch for freeze alarm. Depending on the required performance, coolant type and air parameters, a coil with no more than 3 rows and various evaporation temperatures are installed. The direct coil may be fitted with accessories to order.

CHF.x



Chilled water cooling coil („CHW“)

A built-in coil made of copper pipes and aluminum fins, including a condensate pan with individual condensate drainage. The water cooling coil may be fitted with a R-CHW series control junction on request. If the unit does not contain a hot-water heater, the water cooling coil circuit must be protected using an antifreeze with sufficient thermal resistance, or it must be completely drained for periods when the outside temperature might fall below +5 °C.

CHW.x

Individual modifications can be freely combined

- e.g.:
- DUPLEX-S-BTC (unit with by-pass, hot-water heater and circulation damper)
 - DUPLEX-S-BT-CHF (unit with by-pass, hot-water heater and direct evaporator)
 - DUPLEX-S-BTC-CHP (unit with by-pass, hot-water heater, circulation damper and provision for mounting a cooling coil) etc.

OTHER OPTIONAL ACCESSORIES (BASIC OVERVIEW)

Ke.xxx; Ki.xxx

Shutoff damper e₁; i₁



Shutoff dampers standardly fitted with BELIMO actuators are located in the air inlet port. The following damper types are available:

- fresh air damper e₁ - mandatory for C modification (with mixing damper)
- fresh damper e₁ LF - mandatory for T modification (with heating coil)
- exhaust air damper i₁

Fe.xxx; Fi.xxx

Air filtration



All DUPLEX units can be equipped with class F7 knit filters instead of the standard G4 class. Pressure drop of the filter is then 50 to 100 Pa (clean filter) depending on air flow rate, unit type and dirt accumulated. Optionally, DUPLEX-S 525 - 1400 units may be equipped with class G4 - F7 cassette filters.

R-TPO.x; RS-TPO.x

Heating coil hydraulic kit

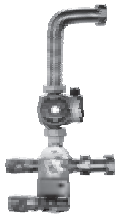

Its function is to control heating capacity of a heating coil. It consists of a three-speed pump, two globe shutoff valves and connection pipes. Further equipment depends on the type:

- R-TPO4 - four-way mixing valve with an actuator for digital control system
- R-TPO3 - three-way mixing valve with an actuator for digital control system
- RS-TPO - three-way diverting valve with a thermostatic valve for electric control system

R-CHW.x

Cooling coil hydraulic kit

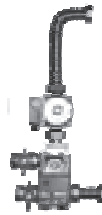

Its function is to control cooling capacity of a chilled-water cooling coil. It always consists of two globe shutoff valves and connection pipes. Further equipment depends on the type:

- R-CHW3 - three-way mixing valve with an actuator and a three-speed pump for digital control system
- R-CHW2 - throttling valve with an actuator for digital control system

H.P

Hingeless doors

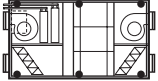

In justified cases a door may be supplied without standard hinges with spring fixtures only. This decreases the necessary handling space in front of the unit.

Flexible connections



Round and rectangular ports can be equipped with flexible connections upon request.

Hot water heating coil (TPO)



Separately supplied coil for installation into round duct.

It is suitable for cramped locations, where it is impossible to put the coil inside the unit, as well as for rooftop units.

The coil is standardly equipped with the steam-gas capillary thermostat.

NFT.x

Spare filter textiles (NFT)



Spare filter textiles in sizes depending on unit type. They are available in the filtration of G4 and F7 class.

RCHF.x

Accessories for DX coil

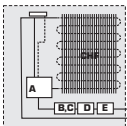

It is possible to equip the DX coils with refrigeration circle components: expansion valve with nozzle (A), solenoid valve (B, C), sight glass (D), filter-drier (E), eventually with evaporating pressure controller.

NFK.x

Spare cassette filters



Spare filter cassettes in sizes depending on the unit type. Supplied in filtration classes G4 and F7. Cassette filters may be fitted to replace knit filters supplied as standard.

CONTROL SYSTEMS

DUPLEX units are delivered with basic control components or with complete control systems. There are three types of control systems available (electric, digital and control for kitchens) according to customer needs and an application. The systems also include variety of sensors (temperature, humidity, air quality, CO₂) for effective operation control.

Features of the control systems

- selection of the most suitable and efficient control system at the lowest cost, depending on the particular application
- control system is integrated with the unit, most components are already wired and checked in factory, thus reducing the risk of incorrect wiring
- no control system project documentation is necessary for standard cases, standardized solutions can be used
- simple wiring, system simplicity, error indication
- qualified technical support and consulting

SUMMARY OF DUPLEX CONTROL SYSTEMS

Type	Characteristics	Use	Simplified diagrams of electrical wiring
„A“ - basic	<ul style="list-style-type: none"> - all electrical components are wired to a junction box terminal strip inside or outside the unit - standard components are fans, damper actuators, capillary freeze protection thermostat of hot water heating coil - more components is included upon customer's request (exact actuator type, sensors, thermostats, pressure switches etc.) 	<ul style="list-style-type: none"> - suitable for applications with separate delivery of control system; e.g. large buildings with central control system etc. 	
„B“ - electric OPS 	<ul style="list-style-type: none"> - simple system - two-speed fan control (MIN, MAX) (exact volume flow rate can individually be set for each fan during commissioning) - on/off control of by-pass and mixing damper - on/off remote control of heating coil: temperature is set on the thermostatic valve of hot water coil or directly on the electric coil 	<ul style="list-style-type: none"> - electric system is suitable for simple applications (e.g. ventilation of locker rooms, gyms, restaurants etc.) - it cannot be used for units with cooling coil - it is recommended for applications with air reheat only (not for warm-air heating) 	
„E“ - digital control series DC 	<ul style="list-style-type: none"> - comfort system of controlling DUPLEX units - the programmable module software has been developed exclusively for DUPLEX units - supply and extraction fan speed control - room or supply temperature control - water / electric heating coil control option - water / direct cooling option - heat pump performance control - automatic by-pass and circulation damper control 	<ul style="list-style-type: none"> - suitable for comfort applications - fully automated operation option with daily or weekly programme - air quality, CO₂ concentration, relative humidity or other sensors may be connected - optional control via a 0 - 10 V signal from a superior system - connectivity to central control systems using expansion cards (KNX, Modbus, ...) - complete set-up using the connected graphic controller possible 	